



MODELL
MØBLER
marine seating



Frédéric OLIVIER
www.prosimar.fr
+33(0) 616 977 845 • fredolivier@prosimar.fr
La Rochelle - France

PROSIMAR
PRO SIÈGES MARINE



Notre société!

La SARL PRO SIEGES MARINE a été créée en 2017 pour prendre la suite des activités maritimes de SERENISEAT (anciennement Atout-Pique) initiées il y a plus de 10 ans.

Basée à La Rochelle, elle opère ses activités de négoce de sièges pour les navires professionnels en France et en Italie.

Acteur fiable et expérimenté, PRO SIEGES MARINE s'appuie sur son expertise et celle des marques leaders qu'elle distribue sous exclusivité pour une vraie relation de confiance avec ses partenaires et clients et pour proposer la meilleure réponse à chaque besoin.

On aime le service!

Vous avez un projet ?

Notre métier est de vous accompagner à choisir le bon produit !

Gamme large, multimarques, énormément de solutions déjà étudiées et définies, des plans 2D et 3D pour vos architectes ou designers, nous avons travaillé en amont pour satisfaire la plupart des demandes !

Vous en voulez plus ? Vous avez un besoin spécifique ? Ok !

On définit un cahier des charges ensemble et on vous propose des solutions sur-mesure avec un 3D pour valider votre plan d'aménagement.

Nous réalisons aussi vos selleries sur mesure.

Nous gérons le transport et les procédures douanières le cas échéant, les documentations techniques.

Nos références...

Nos clients sont nos meilleures références. Pas de petits, pas de gros, tous les projets sont intéressants !

Les marques que nous distribuons livrent dans le monde entier des commandes d'une pièce ou les plus grands chantiers avec des contrats de plusieurs centaines de sièges.

Elles collaborent avec les designers pour des projets de navires de toutes tailles et pour diverses destinations, militaire, yachts, pêche, pilotines, remorqueurs, tankers, ferries...

En France et en Italie, nous sommes fiers d'être sélectionnés par un nombre toujours croissant d'industriels et armements de toutes tailles.



QUELQUES REFERENCES

A/S Hvide Sande Skibs- og
 Baadebyggeri Denmark
 Aker Yards Finland
 Aker Yards Norway
 Astilleros de Sevilla Spain
 Astilleros Zamakona S.A. Spain
 Austal Image Australia
 Austal Ships Pty Australia
 Boghammar Marine A/B Sweden
 Båtservice Mandal A/S Norway
 Carpinteria Elexalde S.A. Spain
 Cassens Werft GmbH Germany
 Cube Design A/S Denmark
 Damen Shipyards Singapore Pte Ltd
 Singapore Damen Shipyard Group
 The Netherlands Danish Interior AS
 Denmark
 Danish Motiva Denmark
 Dansk Boligstål A/S Denmark
 Decon S.A. Greece
 Drammen Skipsreparasjon A.S
 Norway Epsilon Outfitting S.A.
 Greece
 Esbjerg Oilfield Services A/S
 Denmark Fatland AS Norway
 Fidus Innredning AS Norway
 Fincantieri Canteri Navali S.P.A. Italy
 Fjellstrand AS Norway
 Flekkefjord Slipp & maskinfabrikk A/
 S Norway Flensburger Schiffbau-
 Gesellschaft
 MbH & Co. KG Germany
 Fosen Mek Verksteder AS Norway

Geyser S.L. Spain
 Hansen Møbler A/S Denmark
 Hasslø Båtvarv AB Sweden
 HMI Haugland Miljø Innredning AS
 Norway Ippokampos SA Greece
 Lindstøl Skip AS Norway
 Lloyd Werft Bremerhaven GmbH
 Germany Lystad
 Spesialinnredninger AS Norway
 Maderas Jumilla S.A. Spain
 Maritime Montering A/S Norway
 Markhus AS Norway
 Merima OY Finland
 Merwede The Netherlands
 Metalliasennus Huuhka Oy Finland
 MetalShips & Docks, S.A. Spain
 MiTrans AS Norway
 Nam Cheong Dockyard Sdn Bhd
 Malaysia Oliver Design Sociedad
 Ltd. Spain
 Oma Baatbyggeri a.s Norway
 Oma Slipp Og Mek. Verksted AS
 Norway Remontowa S.A. Poland
 San Fernando Shipyard Spain
 ScanMarine Group Of Sweden AB
 Sweden Simek A/S Norway
 Stocznia Gdansk S.A. Poland
 Szczecin Ship Repair Yard "Gryfia"
 Poland Ulstein Verft AS Norway
 Umoe Schat-Harding AS Norway



Frédéric OLIVIER
 www.prosimar.fr
 +33(0) 616 977 845 • fredolivier@prosimar.fr
 La Rochelle - France





SENJA HS

Rails *OPTION*

Légèreté

Ergonomie



ECONOMY CLASS

The "Senja HS" series are designed with maximum seating comfort at a minimum cost. The seats have fixed back and a comfortable ergonomic feature.

The "Senja High HS" has a high back. Armrests are optional.

The "Senja High" is approved according to HSC-2000-Annex 10, level 1 and 2: gcoll up to 12g.

SENJA HS

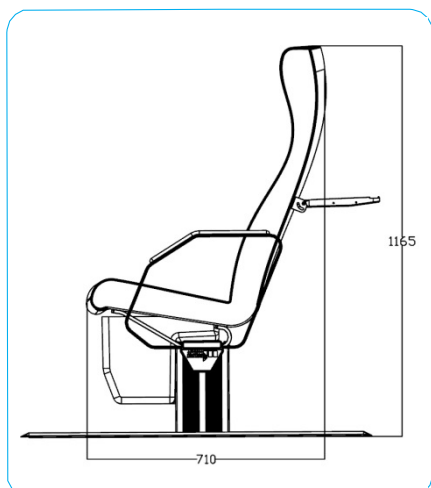
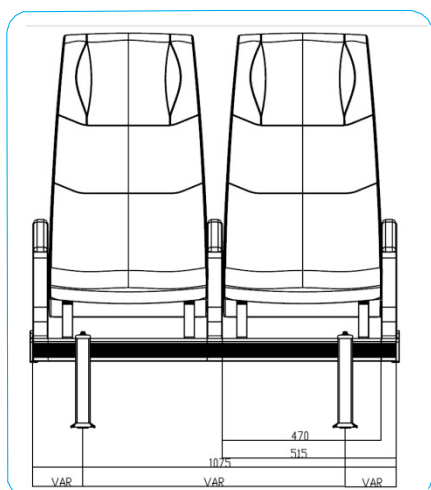
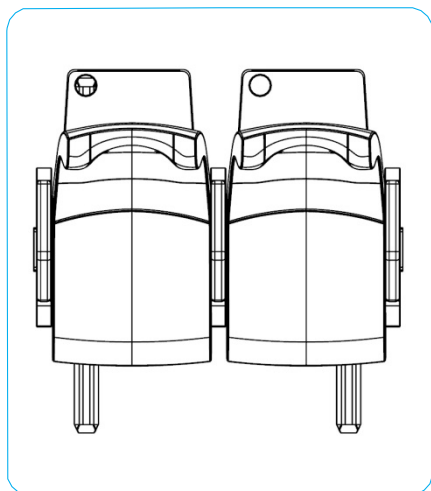

*please reconfirm measurements with company!

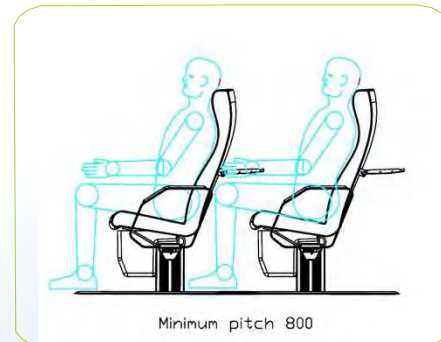

		ARMRESTS – Nos/row								
		0	1	2	3	4	5	6	7	Legs Nos/row
SEATS – Nos/row	1	470	515	560						2
	2	940	985	1030	1075					2
	3	1410	1455	1500		1590				2
	4*	1880	1925	1970			2105			3
	5	2350	2395	2440				2620		3
	6	2820	2865	2910					3135	3

*Weight excl. armrests based on a 4-seat arrangement: apprx. 10 kgs/seat



SENJA HIGH

Rails *OPTION*

Légèreté

Ergonomie



ECONOMY CLASS

The "Senja" series are designed with maximum seating comfort at a minimum cost. The seats have fixed back and a comfortable ergonomic feature.

The "Senja High" has a high back. Armrests are optional.

The "Senja High" is approved according to HSC-2000-Annex 10, level 1 and 2: gcoll up to 12g.

SENJA HIGH

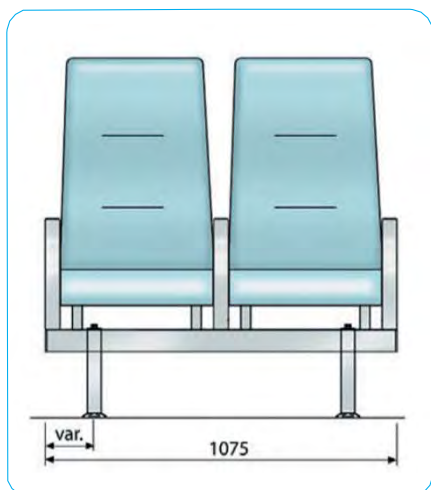
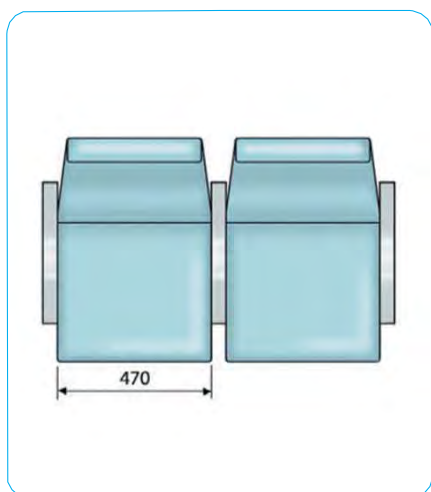
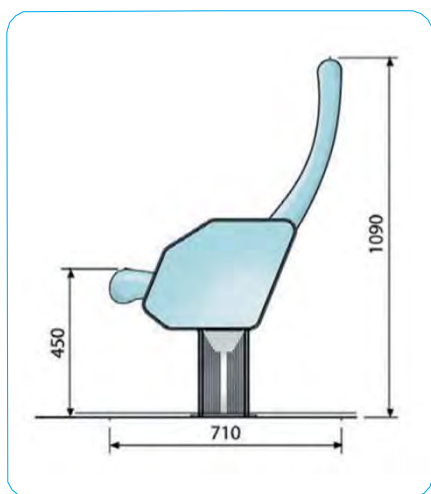

*please reconfirm measurements with company!



		ARMRESTS – Nos/row								
		0	1	2	3	4	5	6	7	Legs Nos/row
SEATS – Nos/row	1	470	515	560						2
	2	940	985	1030	1075					2
	3	1410	1455	1500		1590				2
	4	1880	1925	1970			2105			3
	5	2350	2395	2440				2620		3
	6	2820	2865	2910					3135	3

*Weight excl. armrests based on a 4-seat arrangement: apprx. 10 kgs/seat



SENJA MIDI

Rails *OPTION*

Légèreté

Compacts

Ergonomie



ECONOMY CLASS

The "Senja" series are designed with maximum seating comfort at a minimum cost. The seats have fixed back and a comfortable ergonomic feature.

The "Senja Medium" is delivered with a medium high back. Armrests are optional.

The "Senja Medium" is approved according to HSC-2000-Annex 10, level 1 and 2: gcoll up to 12g.

SENJA MIDI

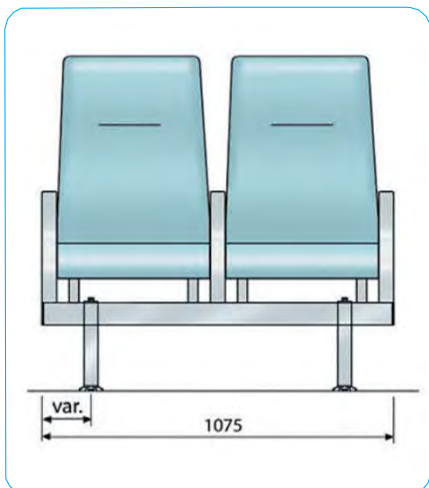
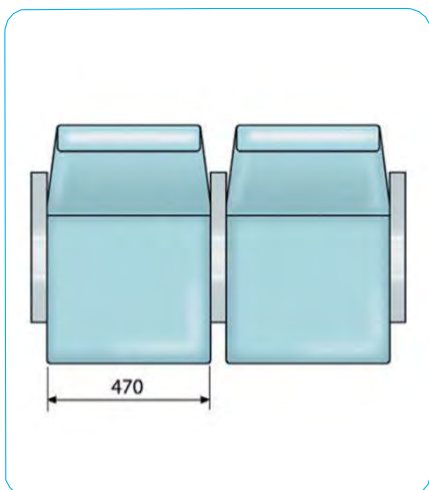
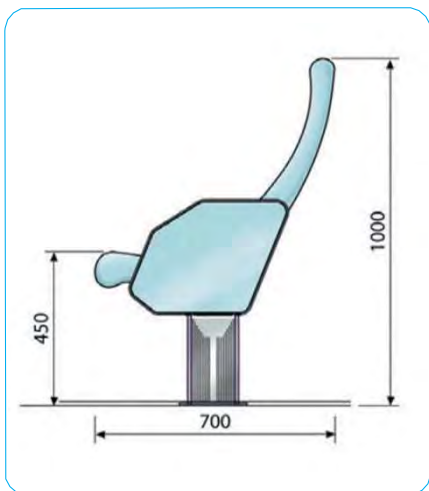

*please reconfirm measurements with company!



		ARMRESTS – Nos/row								
		0	1	2	3	4	5	6	7	Legs Nos/row
SEATS – Nos/row	1	470	515	560						2
	2	940	985	1030	1075					2
	3	1410	1455	1500		1590				2
	4	1880	1925	1970			2105			3
	5	2350	2395	2440				2620		3
	6	2820	2865	2910					3135	3

*Weight excl. armrests based on a 4-seat arrangement: apprx. 10 kgs/seat



SENJA LOW

Rails *OPTION*

Légèreté

Compacts

Ergonomie



ECONOMY CLASS

The "Senja" series are designed with maximum seating comfort at a minimum cost. The seats have fixed back and a comfortable ergonomic feature.

The "Senja Low" has a low back. Armrests are optional.

The "Senja Low" is approved according to HSC-2000-Annex 10, level 1 and 2: gcoll up to 12g.

SENJA LOW

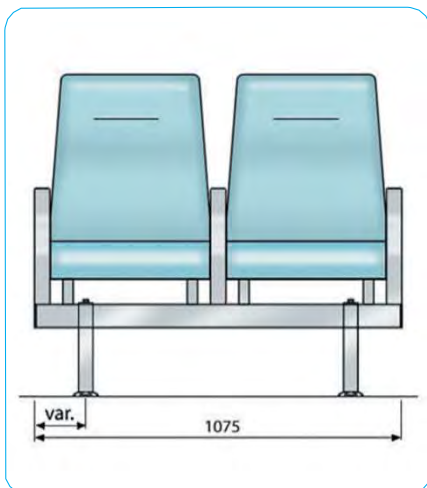
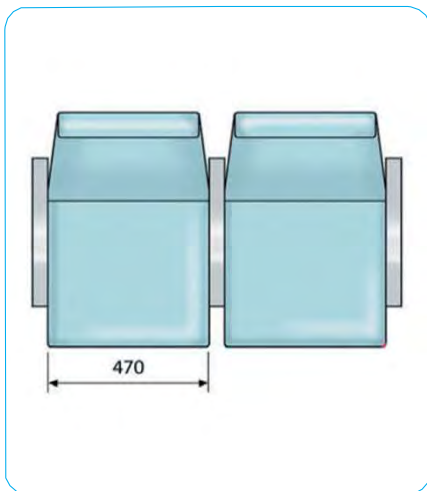
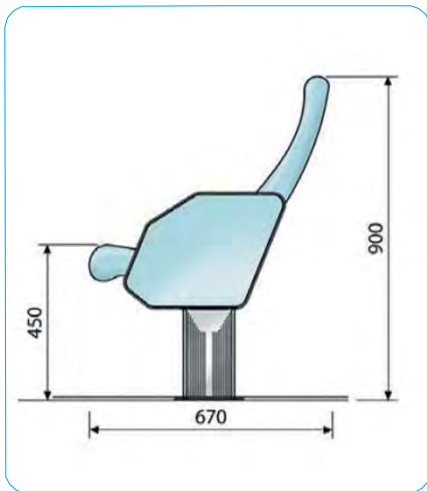

		ARMRESTS – Nos/row								
		0	1	2	3	4	5	6	7	Legs Nos/row
SEATS – Nos/row	1	470	515	560						2
	2	940	985	1030	1075					2
	3	1410	1455	1500		1590				2
	4	1880	1925	1970			2105			3
	5	2350	2395	2440				2620		3
	6	2820	2865	2910					3135	3

*Weight excl. armrests based on a 4-seat arrangement: apprx. 9,5 kgs/seat

*please reconfirm measurements with company!



DIPLOMAT EXTENDED

Rails *OPTION*

Légèreté

Ergonomie



BUSINESS CLASS

The “Bahama 2000 Diplomat extended” offers extra comfort for passengers with a design allowing a more spacious seating experience than standard seating solutions. A chair for those with higher expectations!

The “Bahama 2000 Diplomat extended” offers reclining possibilities down to 45dgr. The seats are delivered with closed armrests as standard for each individual seat.

The “Bahama 2000 Diplomat extended” is approved according to HSC-2000-Annex 10, level 1 and 2: gcoll up to 12g.



Frédéric OLIVIER
www.prosimar.fr
+33(0) 616 977 845 • fredolivier@prosimar.fr
La Rochelle - France

PROSIMAR
PRO SIÈGES MARINE

DIPLOMAT EXTENDED

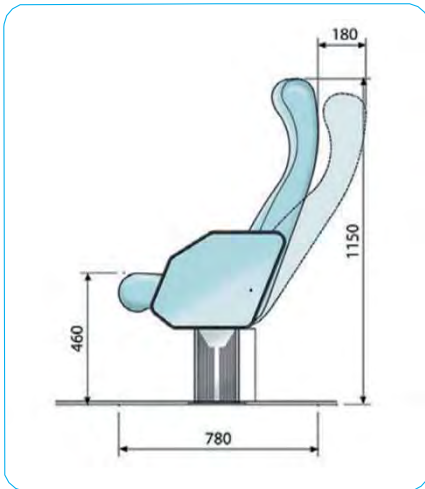

total depth with 45dgr reclining: >1000mm

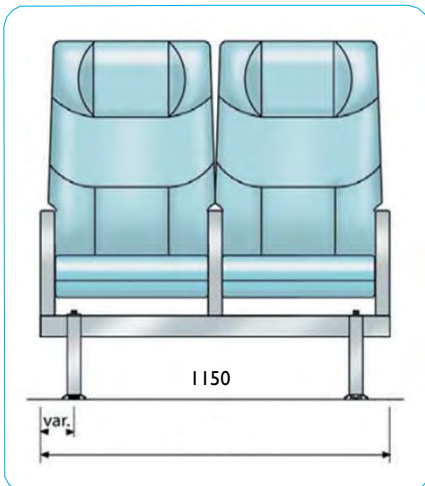
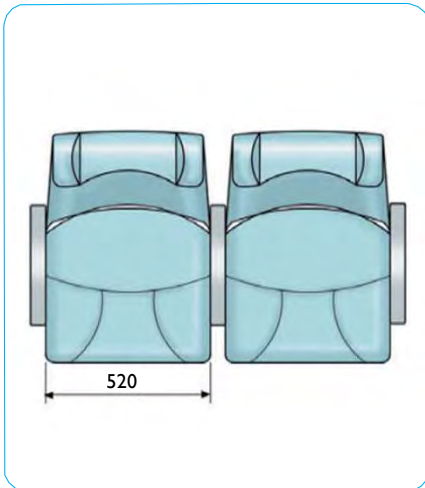

*please reconfirm measurements with company!

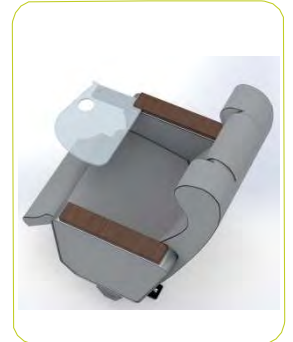
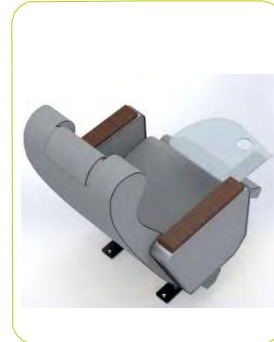

Below form gives total with in mm, Based on number of armrest (90 mm.) per row of seats.

		ARMRESTS – Nos/row							Legs		
		0	1	2	3	4	5	6	7	Nos/row	
SEATS – Nos/row	1	520		700							2
	2	1040			1310						2
	3	1560				1650					2
	4	2080					2530				3
	5	2600						3140			3
	6	3120							3750		3

*Weight excl. armrests based on a 4-seat arrangement: apprx. 14,5 kgs/seat



BAHAMA 2000 DIPLOMAT

Rails *OPTION*

Légèreté

Ergonomie



BUSINESS CLASS

The “Bahama 2000 Diplomat” offers extra comfort for passengers with a design allowing a more spacious seating experience than standard seating solutions. A chair for those with higher expectations!

The “Bahama 2000 Diplomat” offers reclining possibilities down to 45dgr.
The seats are delivered with closed armrests as standard for each individual seat.

The “Bahama 2000 Diplomat” is approved according to HSC-2000-Annex 10 level 1 and 2: gcoll up to 12g.



Frédéric OLIVIER
www.prosimar.fr
+33(0) 616 977 845 • fredolivier@prosimar.fr
La Rochelle - France

PROSIMAR
PRO SIÈGES MARINE

BAHAMAMA 2000 DIPLOMAT

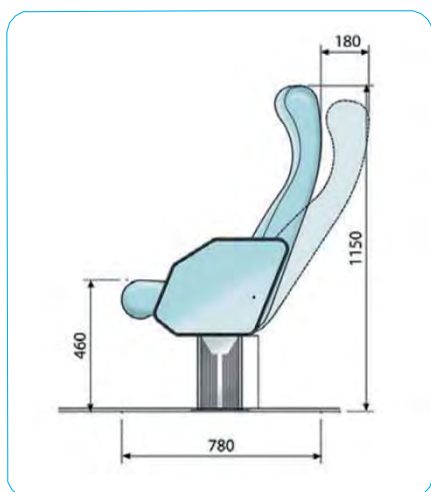

total depth with 45dgr reclining: >1000mm

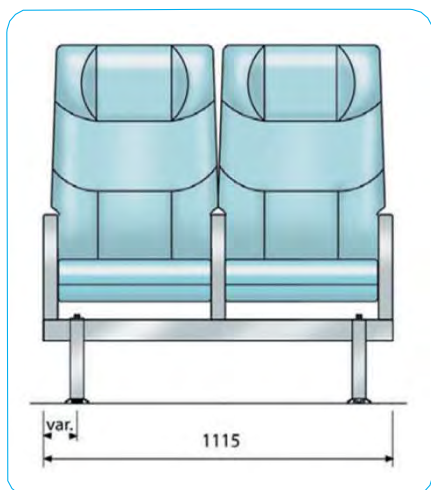
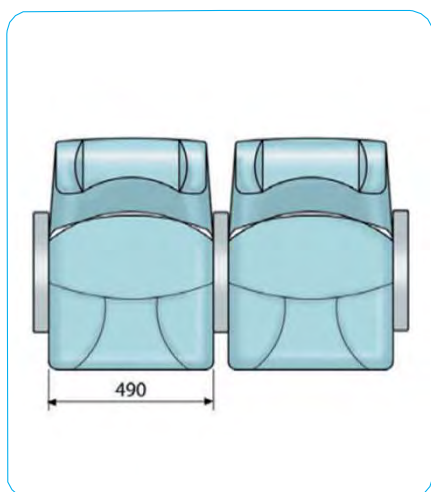

*please reconfirm measurements with company!



		ARMRESTS – Nos/row								
		0	1	2	3	4	5	6	7	Legs Nos/row
SEATS – Nos/row	1	490	535	580						2
	2	980	1025	1070	1115					2
	3	1470	1515	1560		1650				2
	4	1960	2005	2050			2185			3
	5	2450	2495	2540				2720		3
	6	2940	2985	3030					3255	3

*Weight excl. armrests based on a 4-seat arrangement: apprx. 14 kgs/seat



BAHAMA 2000 HS

Rails *OPTION*

Légèreté

Ergonomie



COMFORT CLASS PLUS

The “Bahama 2000 HS” is designed to give passengers a best possible seating experience during the voyage. Reclining, high back and head support as standard features has made this one of our most popular seats. The seats are delivered with closed armrests for each individual seat but other arrangements are available.

The “Bahama 2000 HS” is approved according to HSC-2000-Annex 10, level 1 and 2: gcoll up to 12g.



Frédéric OLIVIER
www.prosimar.fr
+33(0) 616 977 845 • fredolivier@prosimar.fr
La Rochelle - France

PROSIMAR
PRO SIÈGES MARINE

BAHAMAMA 2000 HS

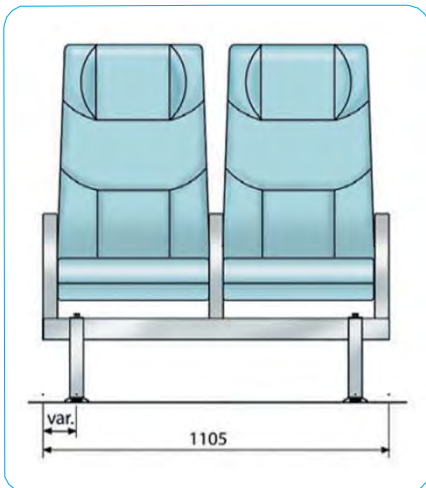
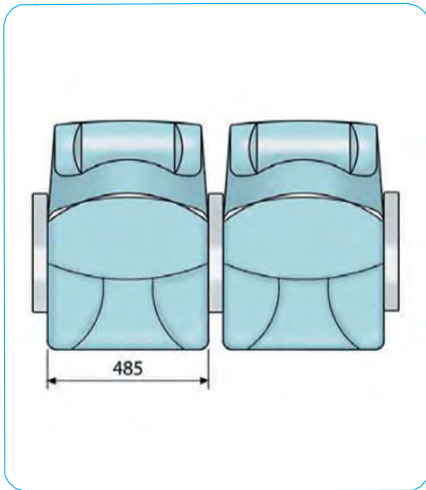
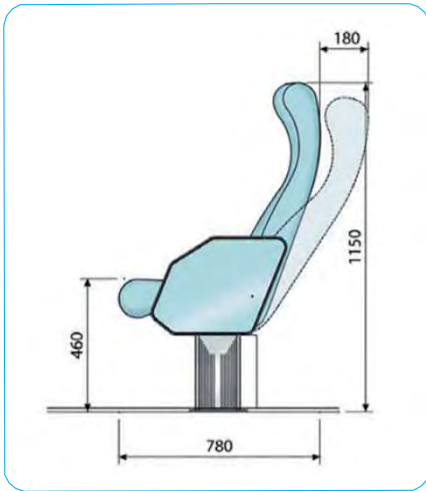

		ARMRESTS – Nos/row								
		0	1	2	3	4	5	6	7	Legs Nos/row
SEATS – Nos/row	1	485	530	575						2
	2	970	1015	1060	1105					2
	3	1455	1500	1545		1635				2
	4*	1940	1985	2030			2165			3
	5	2425	2470	2515				2695		3
	6	2910	2955	3000					3225	3

*Weight excl. armrests based on a 4-seat arrangement: apprx. 13 kgs/seat

*please reconfirm measurements with company!



BAHAMA 2000

Rails *OPTION*

Légèreté

Compacts

Ergonomie



COMFORT CLASS

The “Bahama 2000” is designed to give passengers a best possible seating experience during the voyage. Comfortable features such as reclining and high back are standard. The seats are delivered with closed armrests for each individual seat as standard, but other arrangements are available.

The “Bahama 2000” is approved according to HSC-2000-Annex 10, level 1 and 2: gcoll up to 12g.

BAHAMAMA 2000

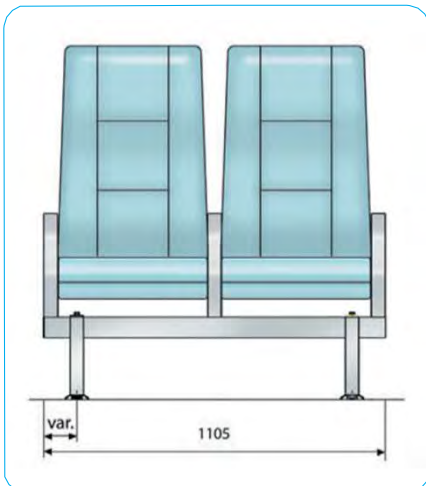
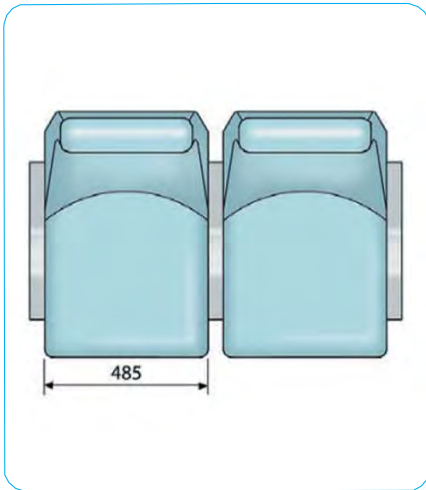
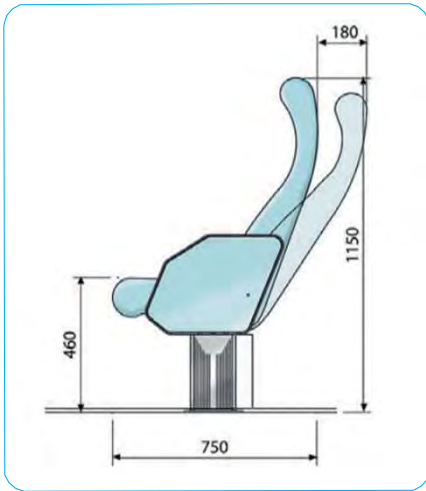

*please reconfirm measurements with company!



		ARMRESTS – Nos/row								
		0	1	2	3	4	5	6	7	Legs Nos/row
SEATS – Nos/row	1	485	530	575						2
	2	970	1015	1060	1105					2
	3	1455	1500	1545		1635				2
	4	1940	1985	2030			2165			3
	5	2425	2470	2515				2695		3
	6	2910	2955	3000					3225	3

*Weight excl. armrests based on a 4-seat arrangement: apprx. 12 kgs/seat



BAHAMA TURN UP

Rails *OPTION*

Légèreté

Compacts

Ergonomie

Rabattables



SPACE SAVER

The “Bahama Turn Up” is designed to allow better passage between seat rows, but at the same time maintain a comfortable seating for the passengers.

Seats are delivered with individual armrests and fully assembled in rows with required number of seats for each row.

The “Bahama Turn Up” is approved according to HSC-2000-Annex 10, level 1 and 2: gcoll up to 12g.

BAHAMA TURN UP

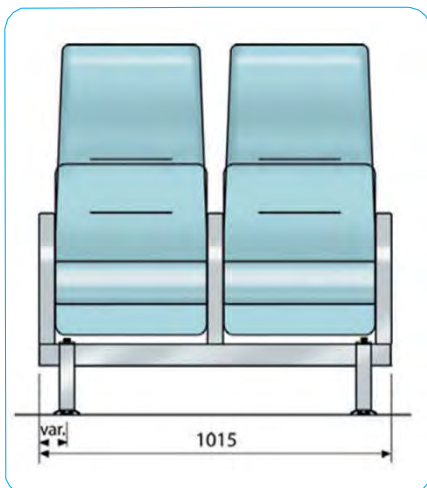
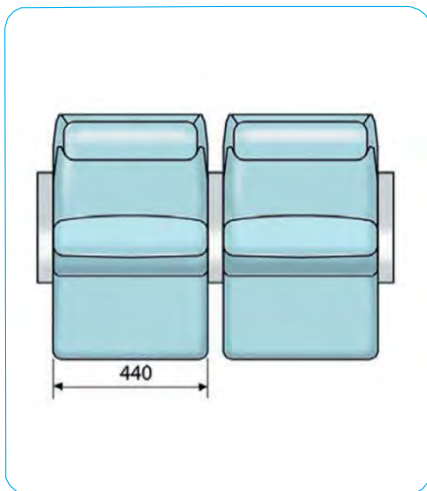
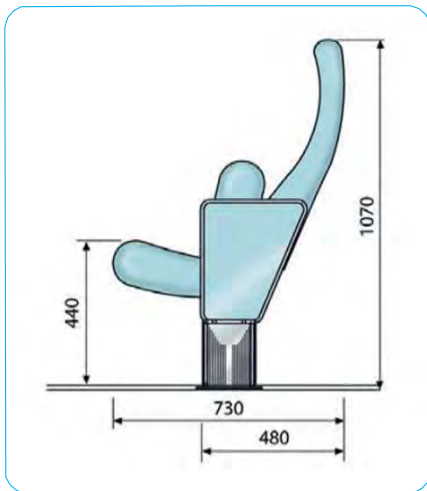

*please reconfirm measurements with company!



		ARMRESTS - Nos/row								
		0	1	2	3	4	5	6	7	Legs Nos/row
SEATS - Nos/row	1	440	485	530						2
	2	880	925	970	1015					2
	3	1320	1365	1410		1500				2
	4	1760	1805	1850			1985			3
	5	2200	2245	2290				2470		3
	6	2640	2685	2730					2955	3

*Weight excl. armrests based on a 4-seat arrangement: apprx. 12 kgs/seat



BAHAMA CINEMA

Rails *OPTION*

Légèreté

Compacts

Ergonomie

Rabattables



SPACE SAVER PLUS

The “Bahama Cinema” is designed to allow better passage between seat rows, but at the same time maintain a comfortable seating for the passengers. The back is lower than our “Bahama Turn Up”, but with the same comfortable ergonomic features.

Seats are delivered with individual armrests and fully assembled in rows with required number of seats for each row.

The “Bahama Cinema” is approved according to HSC-2000-Annex 10, level 1 and 2: gcoll up to 12g.

BAHAMAMA CINEMA

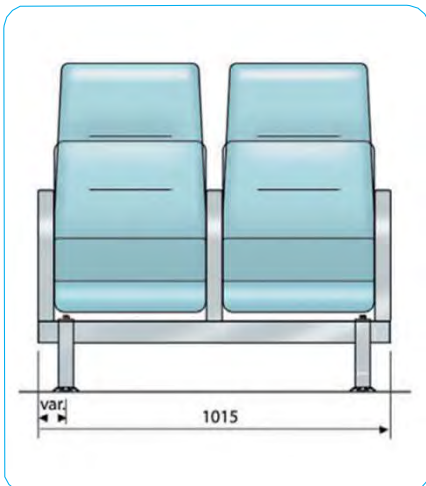
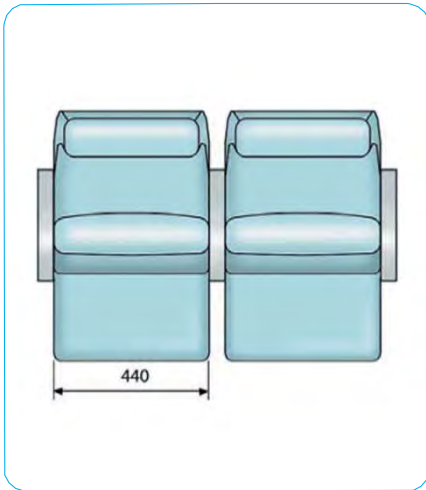
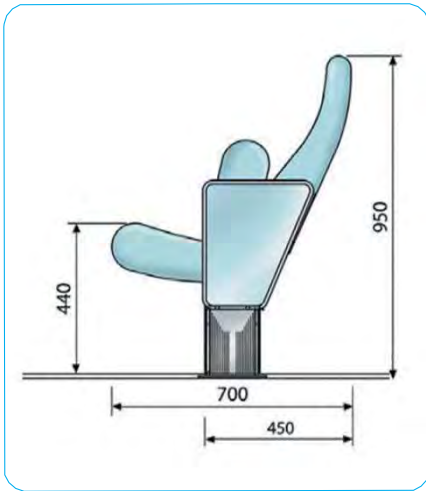

		ARMRESTS - Nos/row								
		0	1	2	3	4	5	6	7	Legs Nos/row
SEATS - Nos/row	1	440	485	530						2
	2	880	925	970	1015					2
	3	1320	1365	1410		1500				2
	4	1760	1805	1850			1985			3
	5	2200	2245	2290				2470		3
	6	2640	2685	2730					2955	3

*Weight excl. armrests based on a 4-seat arrangement: apprx. 11 kgs/seat

*please reconfirm measurements with company!



BAHAMA 4000 TURN UP

Rails *OPTION*

Légèreté

Compacts

Ergonomie

Rabattables



SPACE SAVER PLUS

The “Bahama Cinema” is designed to allow better passage between seat rows, but at the same time maintain a comfortable seating for the passengers. The back is lower than our “Bahama Turn Up”, but with the same comfortable ergonomic features.

Seats are delivered with individual armrests and fully assembled in rows with required number of seats for each row.

The “Bahama Cinema” is approved according to HSC-2000-Annex 10, level 1 and 2: gcoll up to 12g.



Frédéric OLIVIER
www.prosimar.fr
fredolivier@prosimar.fr
La Rochelle - France

PROSIMAR
PRO SIÈGES MARINE

BAHAMAMA 4000 TURN UP

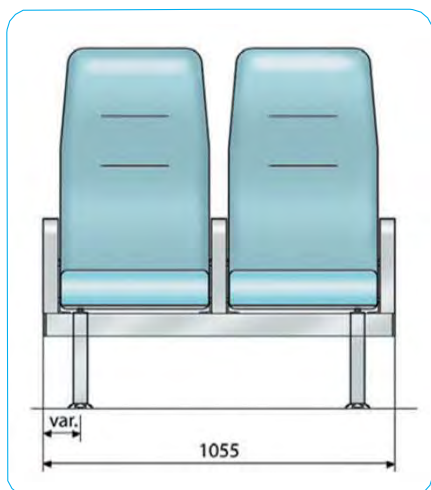
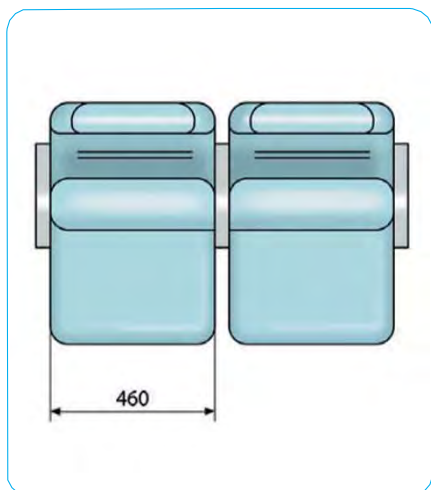
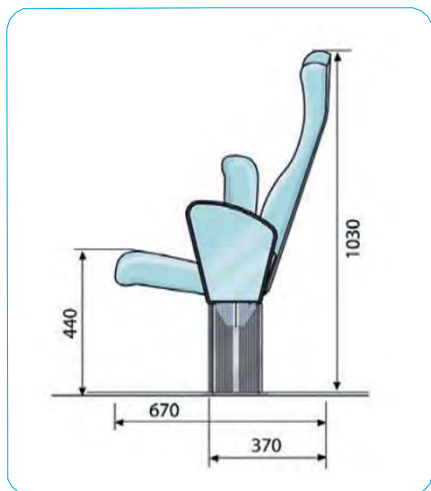

*please reconfirm measurements with company!



		ARMRESTS - Nos/row								
		0	1	2	3	4	5	6	7	Legs Nos/row
SEATS - Nos/row	1	460	505	550						2
	2	920	965	1010	1055					2
	3	1380	1425	1470		1560				2
	4	1840	1885	1930			2065			3
	5	2300	2345	2390				2570		3
	6	2760	2805	2850					3075	3

*Weight excl. armrests based on a 4-seat arrangement: apprx. 10 kgs/seat



BAHAMA TENDER

Rails *OPTION*

Légèreté

Compacts

Ergonomie

Rabattables



SPACE SAVER

The "Bahama tender Turn Up" has the same ergonomic features as our "Bahama Cinema" and "Bahama Turn Up". Armrests are optional.

The "Bahama tender Turn Up" up is designed to allow better passage between seat rows, but at the same time maintain a comfortable seating for the passengers. The flip up seat cushion system, is patent pending, its made totally without springs. When you pull the seat down, it will stay it that position, and when you push the seat up, it will stay in that position. The frame is built to give low weight, and the best comfort.



Frédéric OLIVIER
www.prosimar.fr
+33(0) 616 977 845 • fredolivier@prosimar.fr
La Rochelle - France

PROSIMAR
PRO SIÈGES MARINE

BAHAMA TENDER



The “Bahama tender Turn Up” up is designed to allow better passage between seat rows, but at the same time maintain a comfortable seating for the passengers. The reclining system is patent pending, its made without any springs. When you pull the seat down, it will stay in that position, and when you push the seat up, it will stay in that position. The frame is built up with nozag feather molded into seat and backrest, to give low weight, and the best comfort.

BAHAMA TENDER

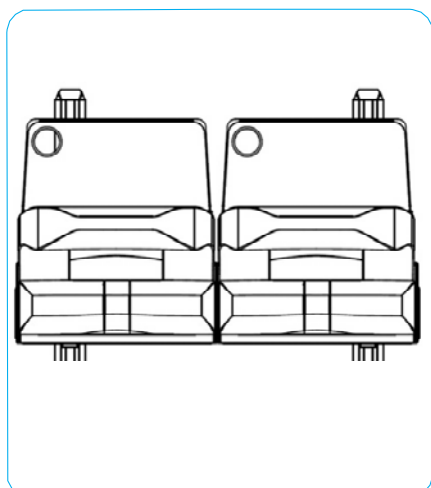
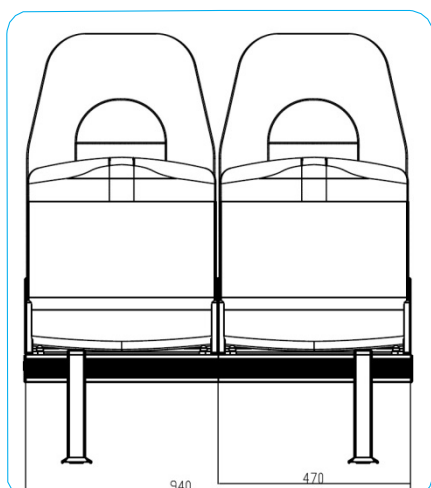
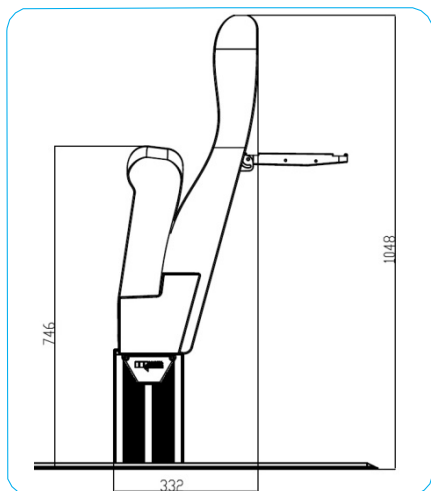

*please reconfirm measurements with company!



		ARMRESTS – Nos/row								
		0	1	2	3	4	5	6	7	Legs Nos/row
SEATS – Nos/row	1	470	515	560						2
	2	940	985	1030	1075					2
	3	1410	1455	1500		1590				2
	4*	1880	1925	1970			2105			3
	5	2350	2395	2440				2620		3
	6	2820	2865	2910					3135	3

*Weight excl. armrests based on a 4-seat arrangement: apprx. 7 kgs/seat



SENJA OUTDOOR

Rails *OPTION*

Outdoor

Légèreté

Compacts



OUTDOOR SEATING

The "Senja Outdoor" is an all weather chair with foldable back, mounted on the same beam and legs as the other chairs in Modell Møbler's range.

The chair is delivered without armrests as standard.

SENJA OUTDOOR

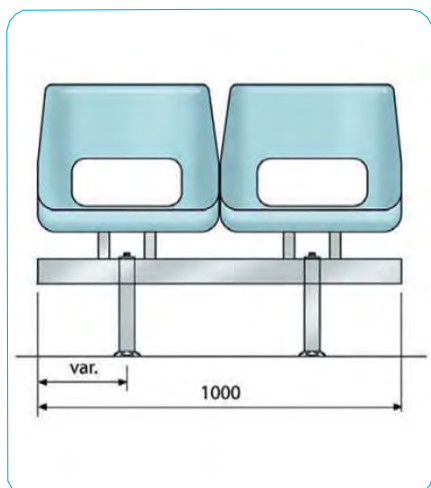
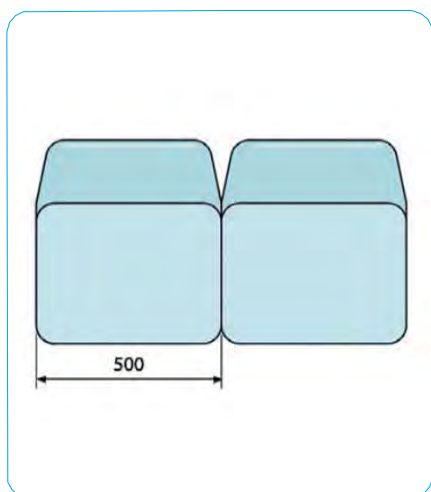
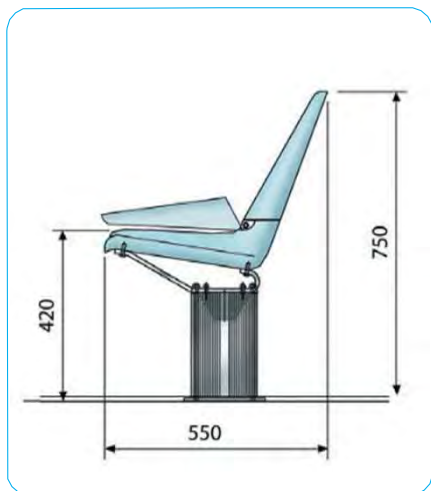

		ARMRESTS – Nos/row								
		0	1	2	3	4	5	6	7	Legs Nos/row
SEATS – Nos/row	1	500								2
	2	1000								2
	3	1500								2
	4	2000								2
	5	2500								2/3
	6	3000								3

*Weight based on a 4 seat arrangement incl. beam and legs: apprx. 5kgs/seat

*please reconfirm measurements with company!



WALL MOUNTED SEAT

Légèreté

Compacts

Rabattables

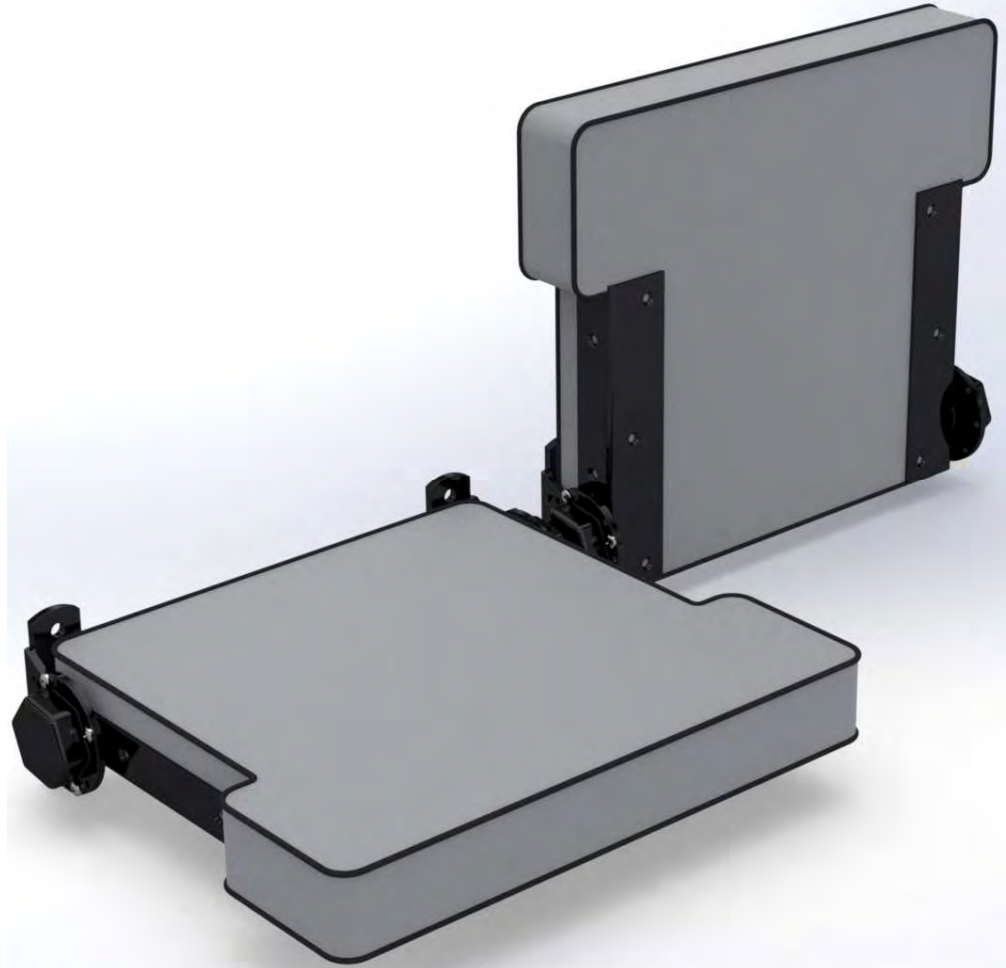

SPACE SAVER

The wall mounted seat, is for use on places where you should have a seat, but there is no space for it. The bracket has a strong feather inside, so it will stay in upright position when not in use.

WALL MOUNTED SEAT

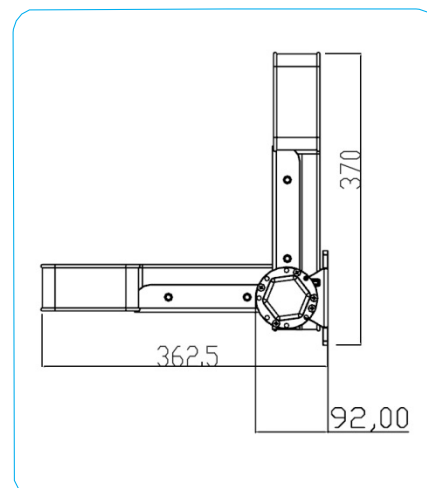
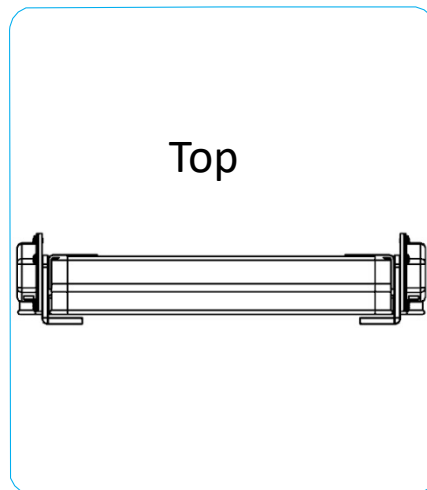
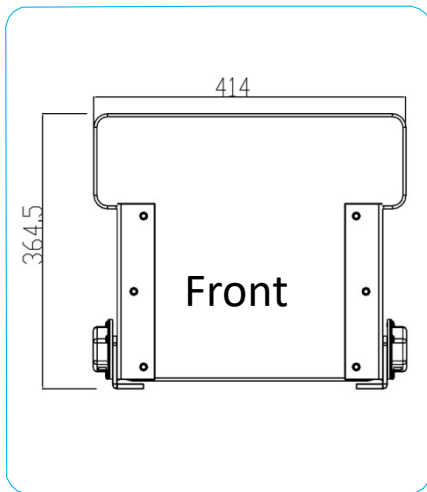

*please reconfirm measurements with company!

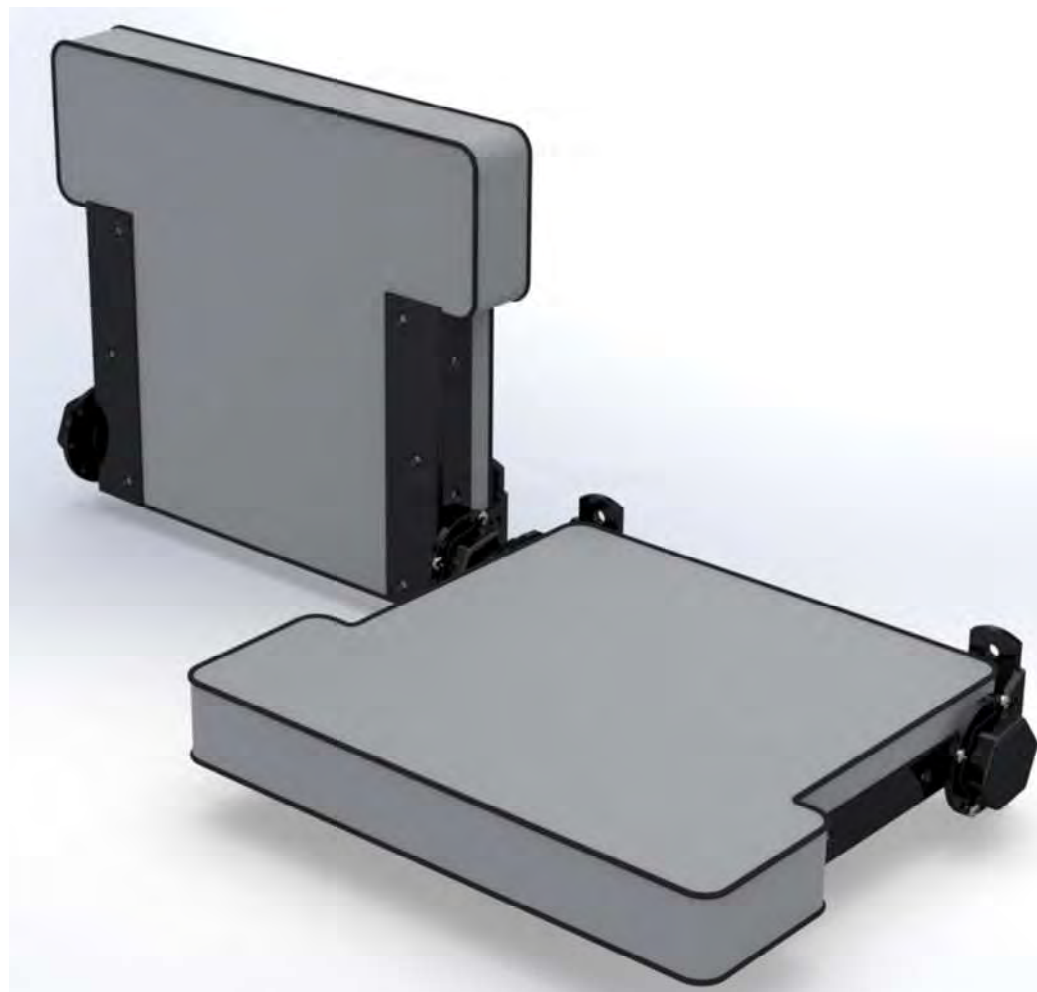



PULL UP SEAT

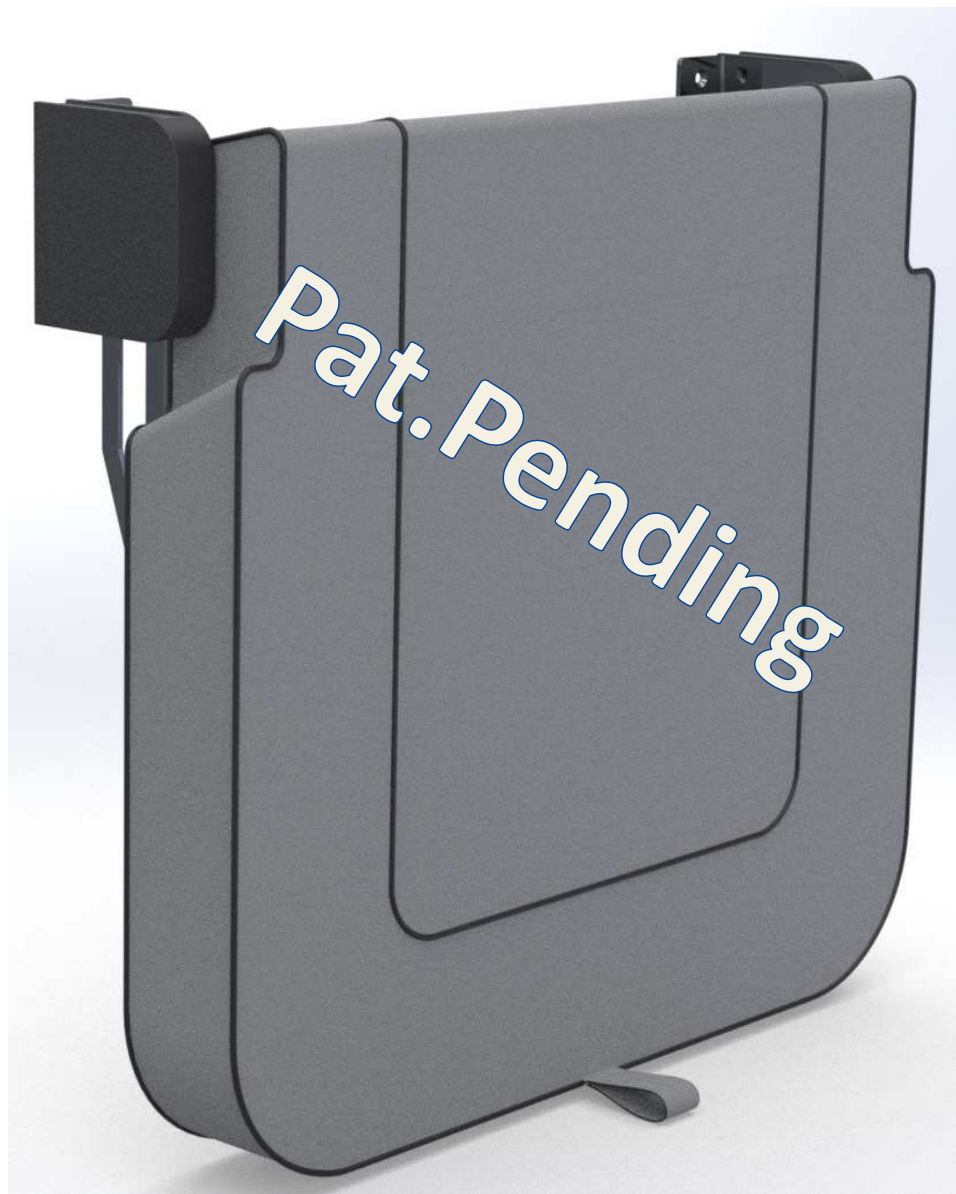

Légèreté

Compacts

Rabattables

SPACE SAVER

The wall mounted pullup seat is for use where there is less space for seating. Since this seat is pulled up, it will not steal any space over the seat. You could mount it under a window. When you pull up the seat, it snaps into position and stays there. To unlock it again, push it up and back, and it will snap into its lower position and stay there. The seat should be mounted about 450 mm above the floor. The hinge is patent pending.



Frédéric OLIVIER
www.prosimar.fr
+33(0) 616 977 845 • fredolivier@prosimar.fr
La Rochelle - France

PROSIMAR
PRO SIÈGES MARINE

PULL UP SEAT

Pat. Pending

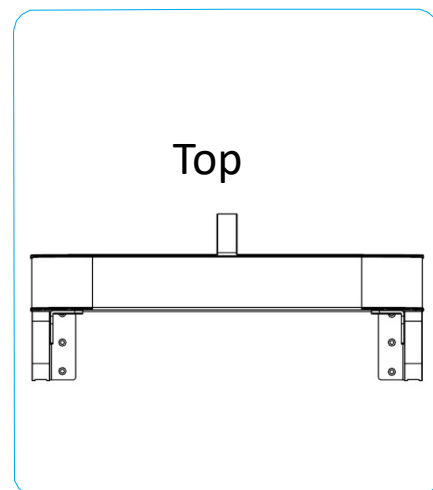
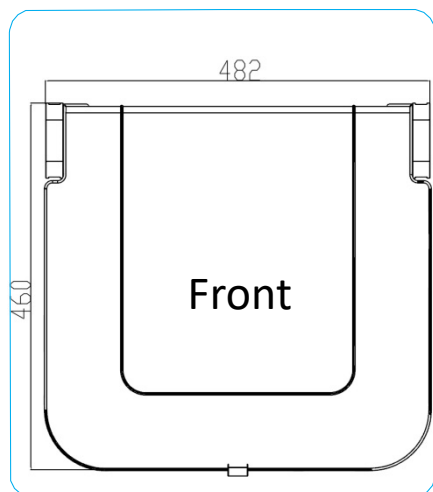
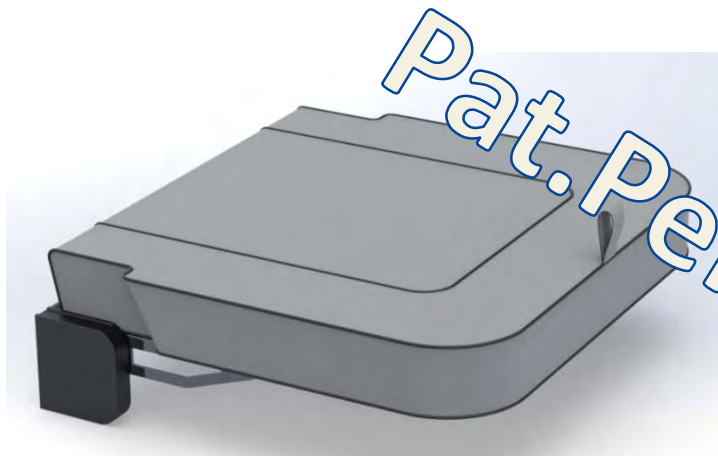

*please reconfirm measurements with company!

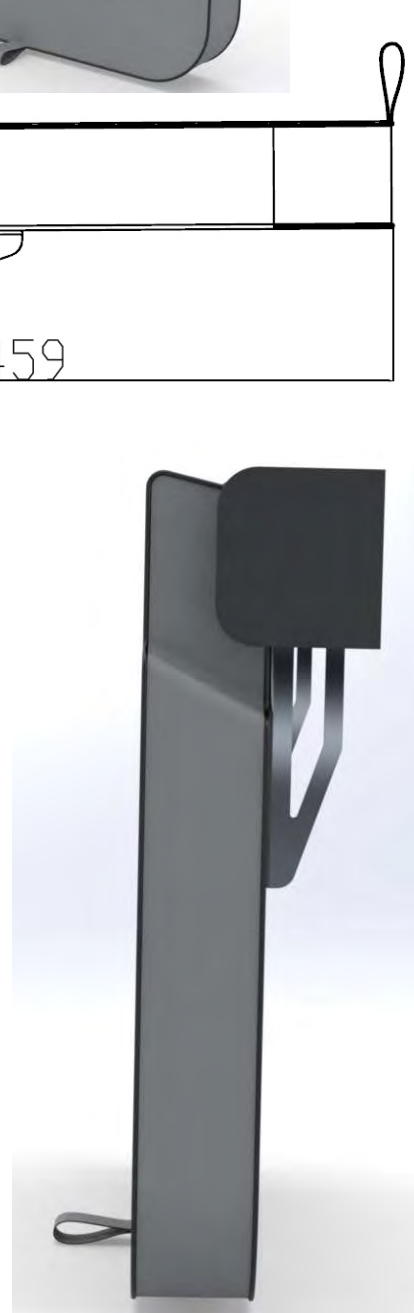
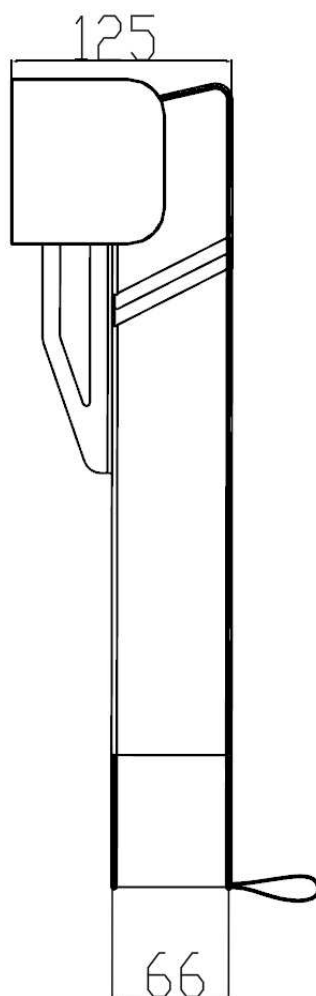
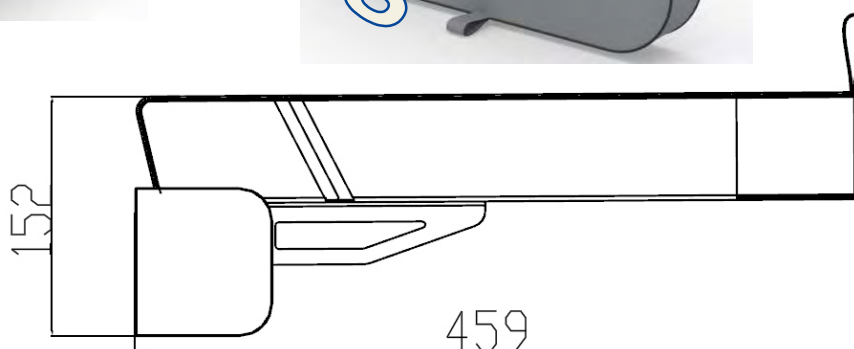



CUSTOM MADE SEAT

Rails *OPTION*

Outdoor

Légèreté

Compacts

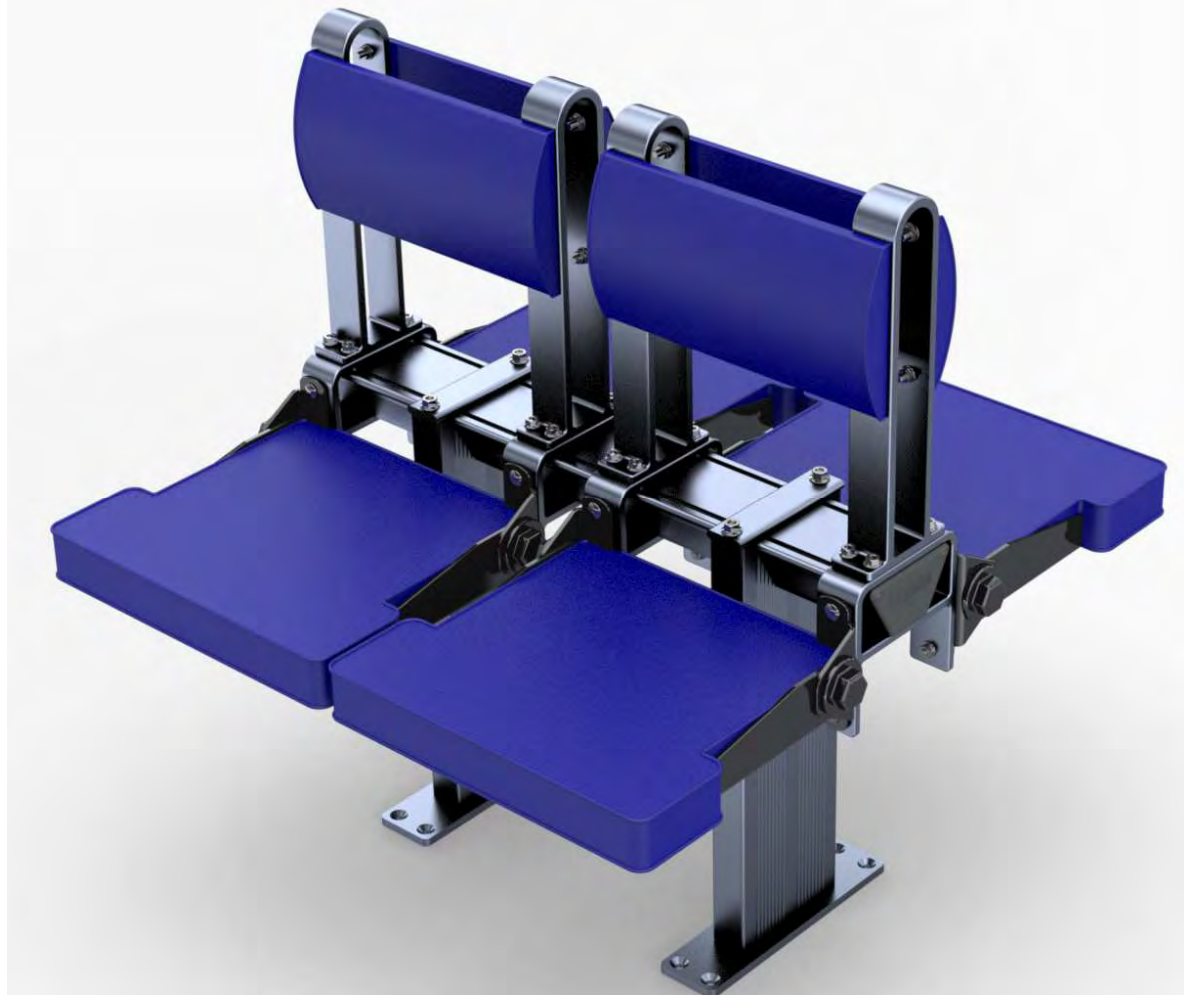

SPACE SAVER

The wall mounted seat, is for use on places where you should have a seat, but there is no space for it. The bracket has a strong feather inside, so it will stay in upright position when not in use.



Frédéric OLIVIER
www.prosimar.fr
+33(0) 616 977 845 • fredolivier@prosimar.fr
La Rochelle - France

PROSIMAR
PRO SIÈGES MARINE

CUSTOM MADE SEAT

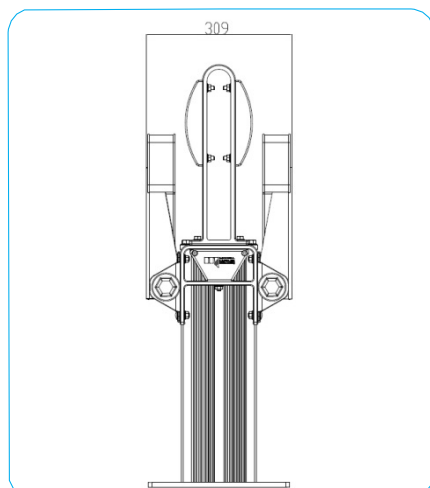
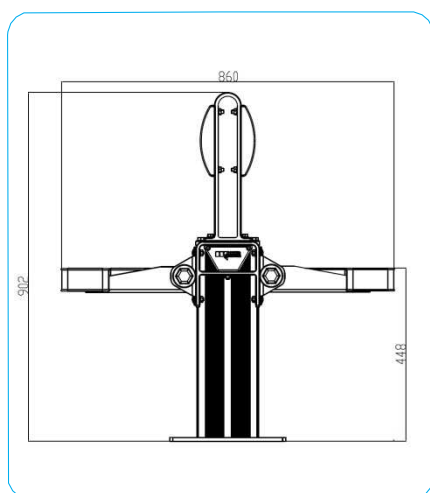
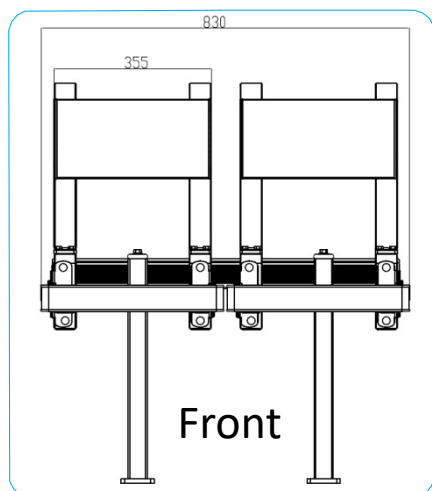

*please reconfirm measurements with company!

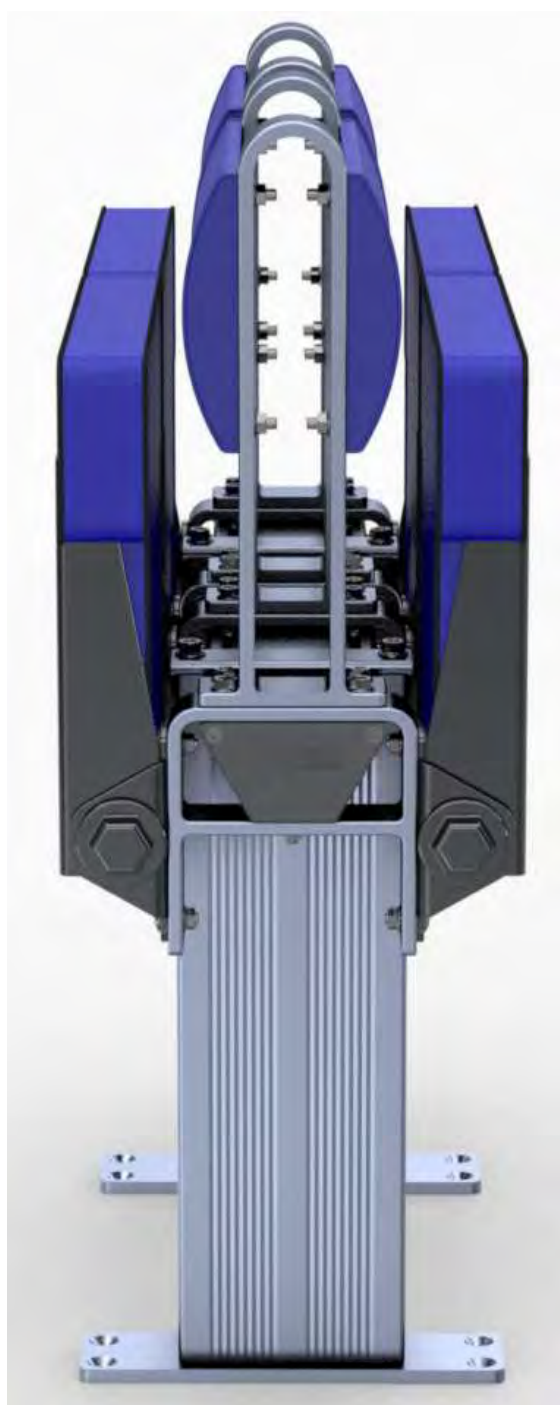



PULL UP TABLE



Légèreté

Compacts

Rabattables

SPACE SAVER

The wall mounted pullup table, is for use where there is less space. Since this table is pulled up, it will not steal any space over the table. You could mount in under a window. You dont have to deal with any legs, or brackets to hold it in position. Just pull it up and it snaps into place and stay there. To unlock it again, push it up and back, and it will snap into its lower position and stay there. The table should be mounted about 700 mm above the floor. The hinge is patent pending. The size could vary, or you could just buy the hinge.



Frédéric OLIVIER
www.prosimar.fr
+33(0) 616 977 845 • fredolivier@prosimar.fr
La Rochelle - France





PULL UP TABLE



SPACE SAVER

The wall mounted pullup table, is for use where there is less space. Since this table is pulled up, it will not steal any space over the table. You could mount in under a window. You dont have to deal with any legs, or brackets to hold it in position. Just pull it up and it snaps into place and stay there. To unlock it again, push it up and back, and it will snap into its lower position and stay there. The table should be mounted about 700 mm above the floor. The hinge is patent pending. The size could vary, or you could just buy the hinge.

PULL UP TABLE

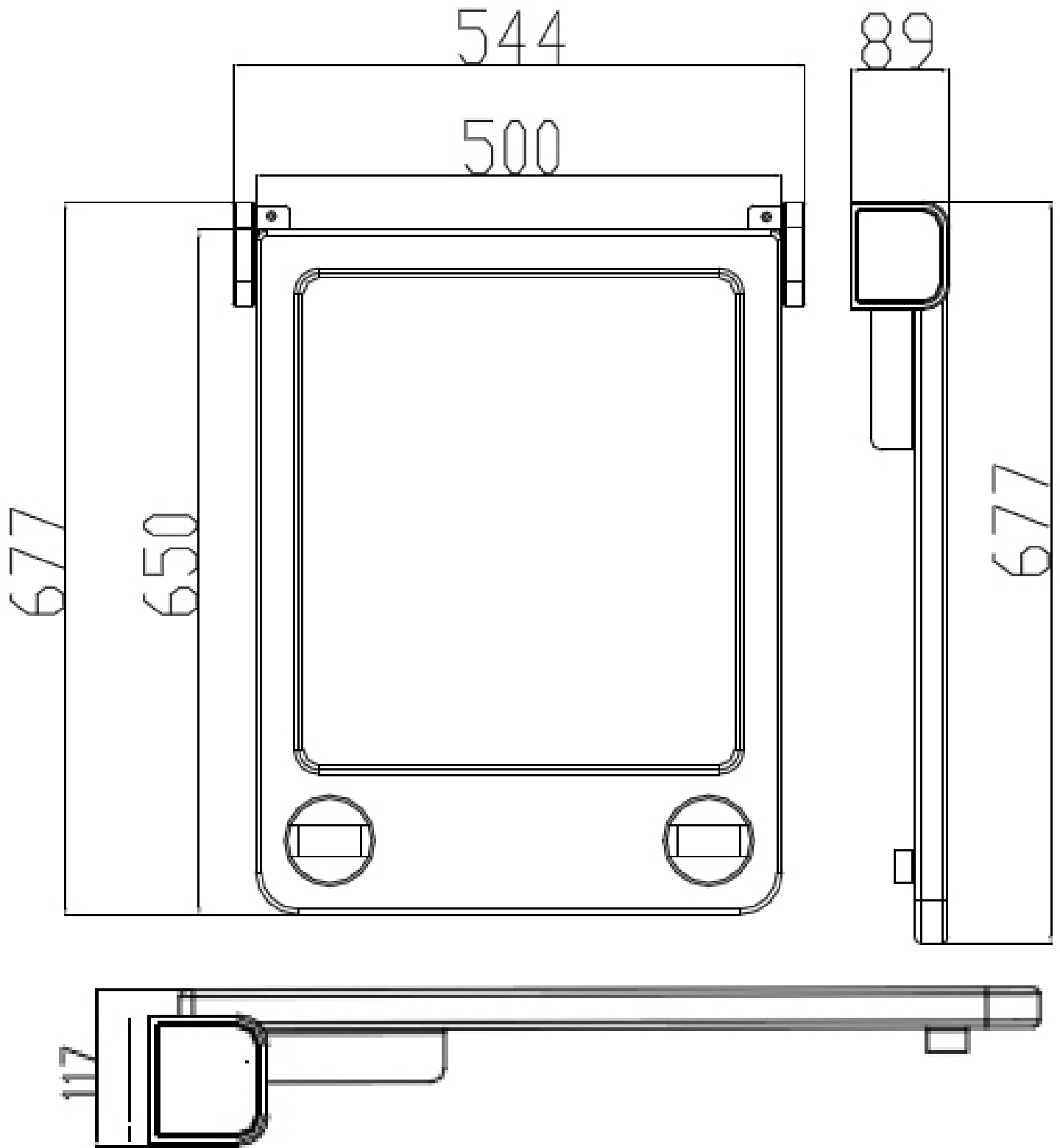



SENJA CREW

Rails *OPTION*

Outdoor

Légèreté

Compacts



OUTDOOR SEATING

The "Senja Crew" is an all weather chair with removable easy to change fabric, mounted on the same beam and legs as the other chairs in Modell Møbler's range.

The chair is delivered without armrests as standard.



Frédéric OLIVIER
www.prosimar.fr
fredolivier@prosimar.fr
La Rochelle - France

PROSIMAR
PRO SIÈGES MARINE

SENJA CREW

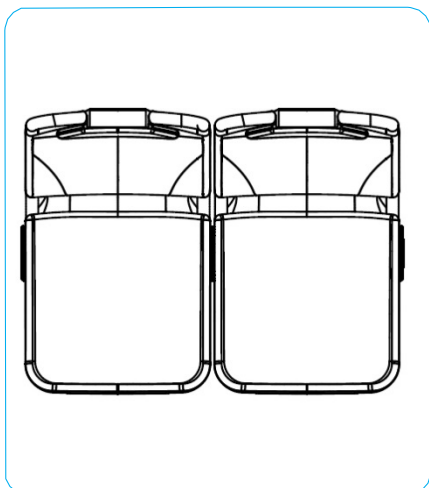
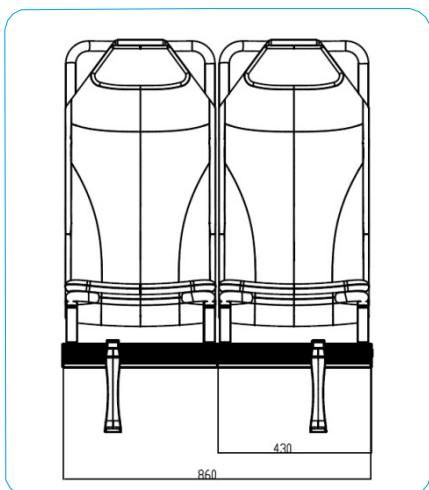
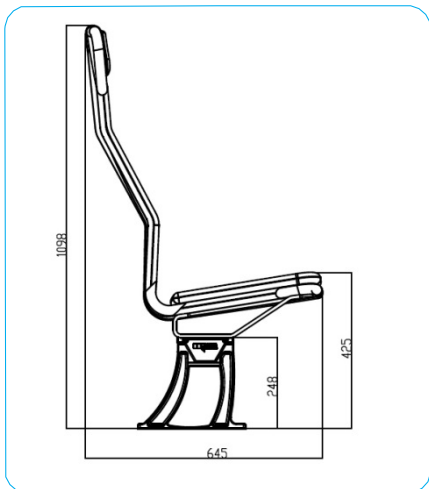

*please reconfirm measurements with company!

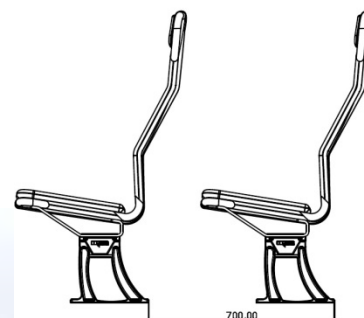

		ARMRESTS – Nos/row								
		0	1	2	3	4	5	6	7	Legs Nos/row
SEATS – Nos/row	1	500								2
	2	1000								2
	3	1500								2
	4*	2000								2
	5	2500								2/3
	6	3000								3

*Weight based on a 4 seat arrangement incl. beam and legs: apprx. 7kgs/seat



OUTDOOR BENCHES



Rails *OPTION*

Outdoor

Légèreté

OUTDOOR SEATING

Outdoor benches, produced after customers request. Mounted on the same beam and legs as the other chairs in Modell Møbler's range.



Frédéric OLIVIER
www.prosimar.fr
+33(0) 616 977 845 • fredolivier@prosimar.fr
La Rochelle - France

PROSIMAR
PRO SIÈGES MARINE



OUTDOOR BENCHES



Rails *OPTION*

Outdoor

Légèreté



OUTDOOR SEATING

Outdoor benches, produced after customers request. Mounted on the same beam and legs as the other chairs in Modell Møbler's range.



Frédéric OLIVIER
www.prosimar.fr
+33(0) 616 977 845 • fredolivier@prosimar.fr
La Rochelle - France





OUTDOOR BENCHES



Rails *OPTION*

Outdoor

Légèreté



OUTDOOR SEATING

Outdoor benches, produced after customers request. Mounted on the same beam and legs as the other chairs in Modell Møbler's range.



Frédéric OLIVIER
www.prosimar.fr
+33(0) 616 977 845 • fredolivier@prosimar.fr
La Rochelle - France

PROSIMAR
PRO SIÈGES MARINE

OUTDOOR BENCHES

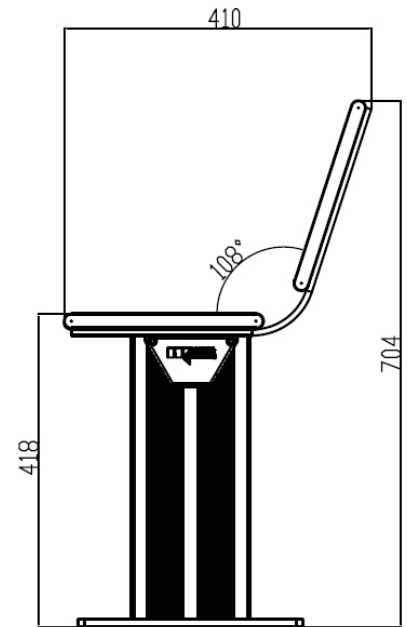
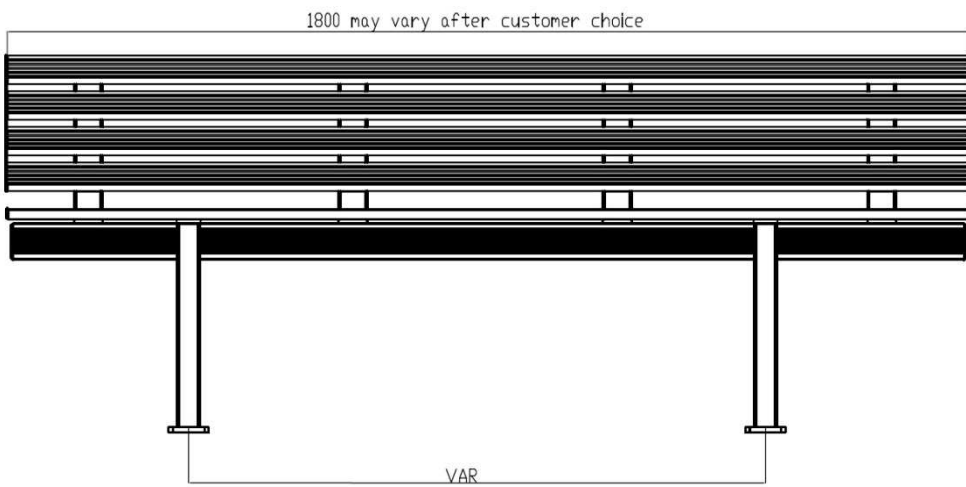
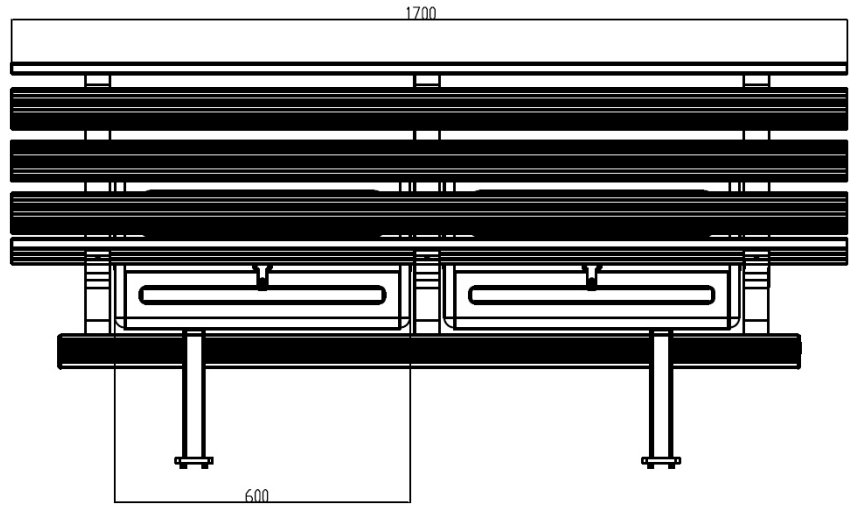
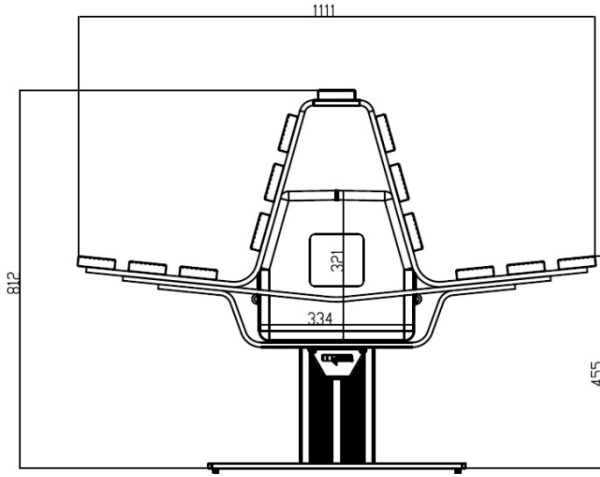



TABLES



Rails *OPTION*

Outdoor *OPTION*

Légèreté

Tables are delivered in several executions The standardized legs fits perfectly to the floor rail system or may be fitted directly to the floor by means of a base plate. The legs may be delivered separately without the table tops.



CLUB

Légèreté

Compacts



Indoor furniture

The "CLUB CHAIR" is an all round chair for use in restaurants, or other places where there is loose furnitures. The chair could be fittet with aluminium plate in bottom, so it could be mounted to the floor. And with coverplate in front, there is also space to hide the life jackets



Frédéric OLIVIER
www.prosimar.fr
+33(0) 616 977 845 • fredolivier@prosimar.fr
La Rochelle - France

PROSIMAR
PRO SIÈGES MARINE

CLUB

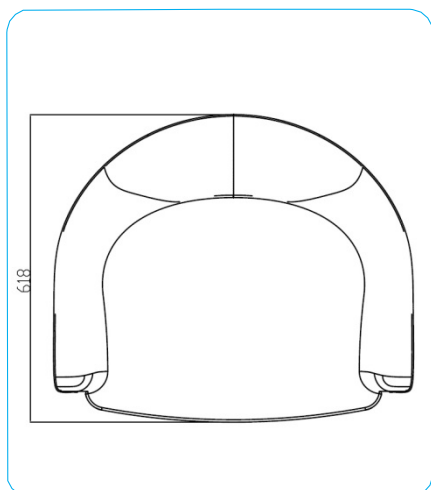
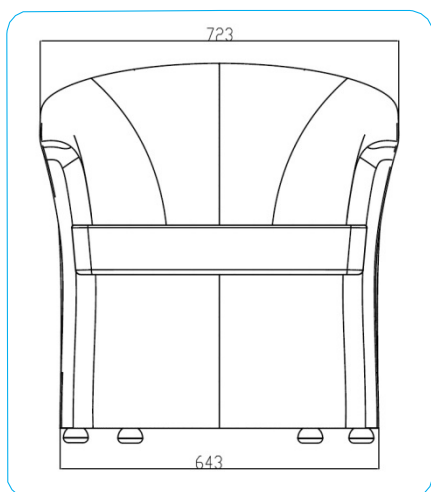
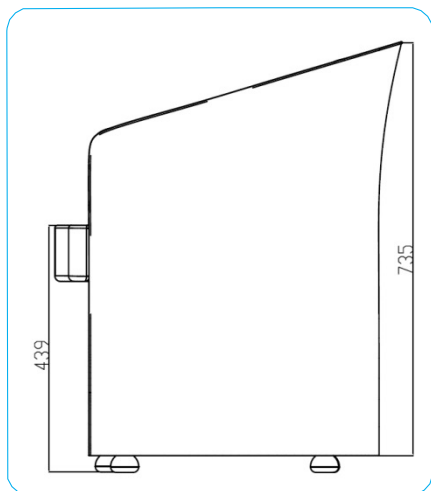

*please reconfirm measurements with company!

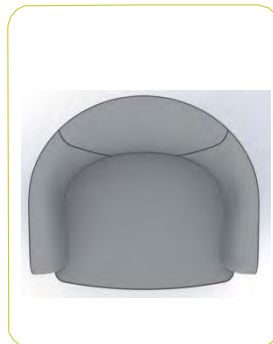

		ARMRESTS – Nos/row								
		0	1	2	3	4	5	6	7	Legs Nos/row
SEATS – Nos/row	1	500								2
	2	1000								2
	3	1500								2
	4*	2000								2
	5	2500								2/3
	6	3000								3

*Weight apprx. 15kgs/ seat



ECON SOFA

Built up by single powercoated aluminium frames.



50 or 55 cm modules

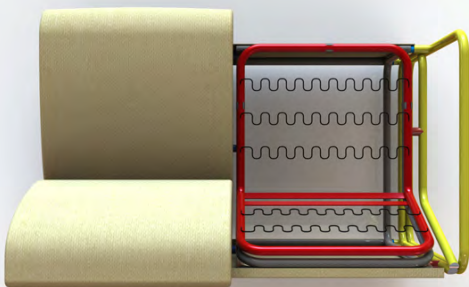

Storage under the seat

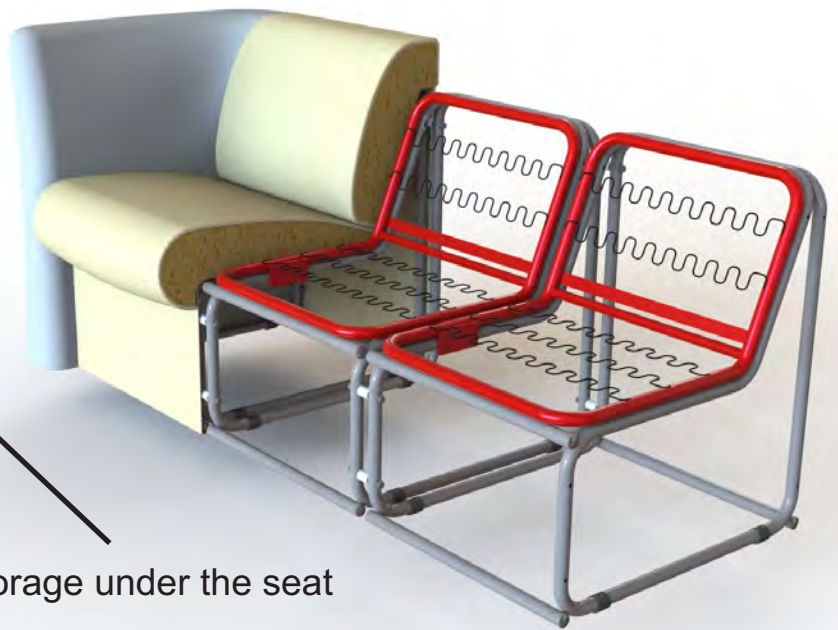

26,5 x 56,5 x 52,0 cm
Almost 0,1 m³

One module is tested with 1000 kg weight on it

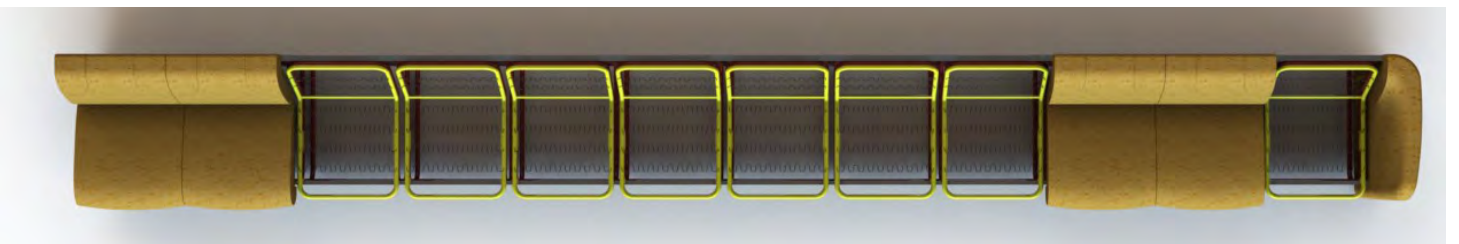

CONTRACT FURNITURE



“Modell Møbler has made sizable deliveries of special designed furniture in connection with both restoring and new construction of cruise liners, fast ferries and oil rig platforms.”

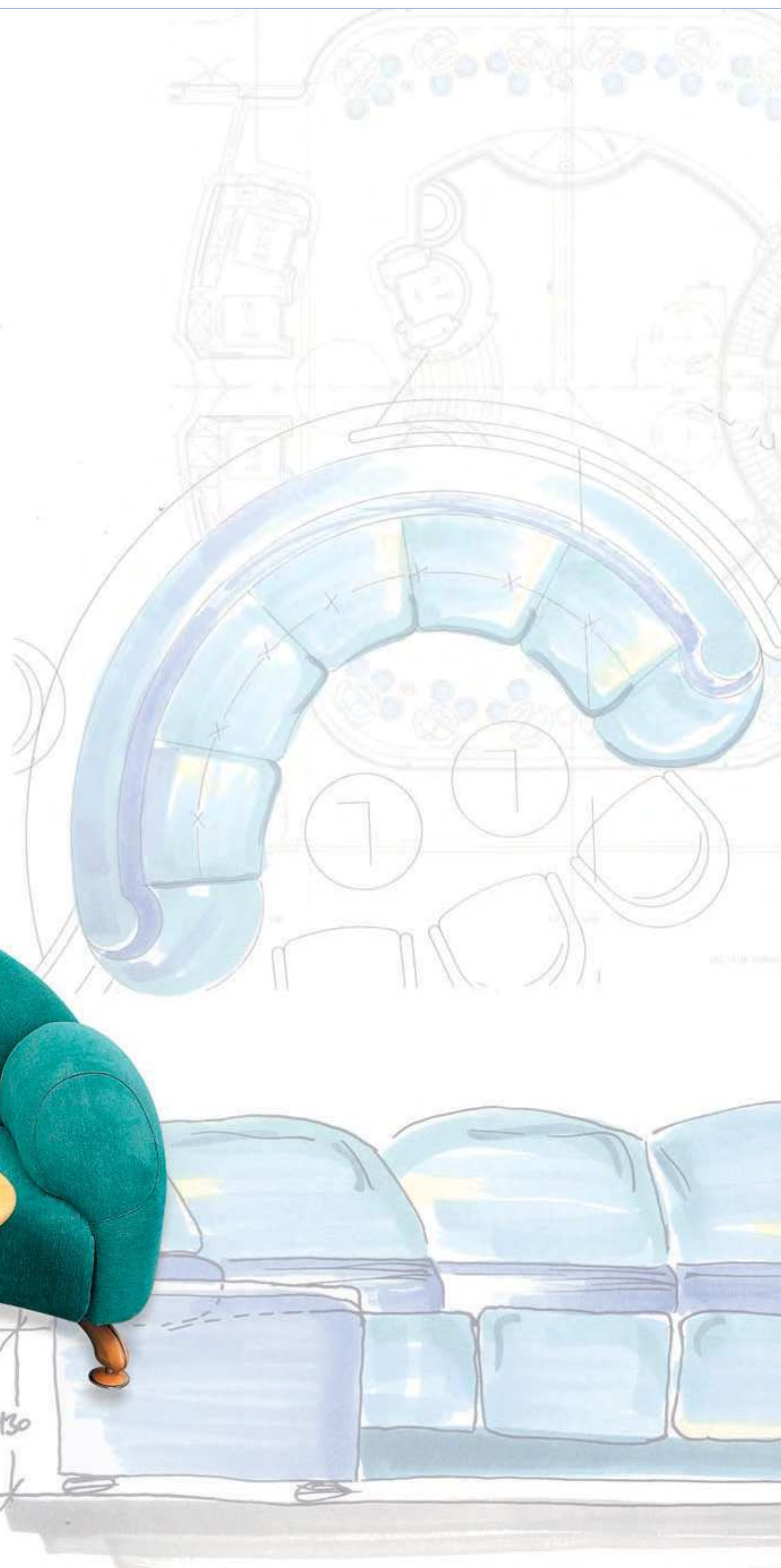

“Images by compliments from architect Njål R. Eide”

“The cruise market has long been one of our important markets in addition to the marine seats. We manufacture furniture in close co-operation with our customers to design products tailored to their specific requirements, paying close attention to quality and design.”

CONTRACT FURNITURE



“Modell-Møbler is a niche maritime furniture supplier able to provide custom products in short delivery timeframes.

Our comprehensive product range enables us to supply most furniture markets such as hotels, restaurants, offices, cinemas and theatres, ferries and catamarans, offshore installations, cruise ships and pleasure crafts.

Our idea is to convert your designs from ideas into finished products.”

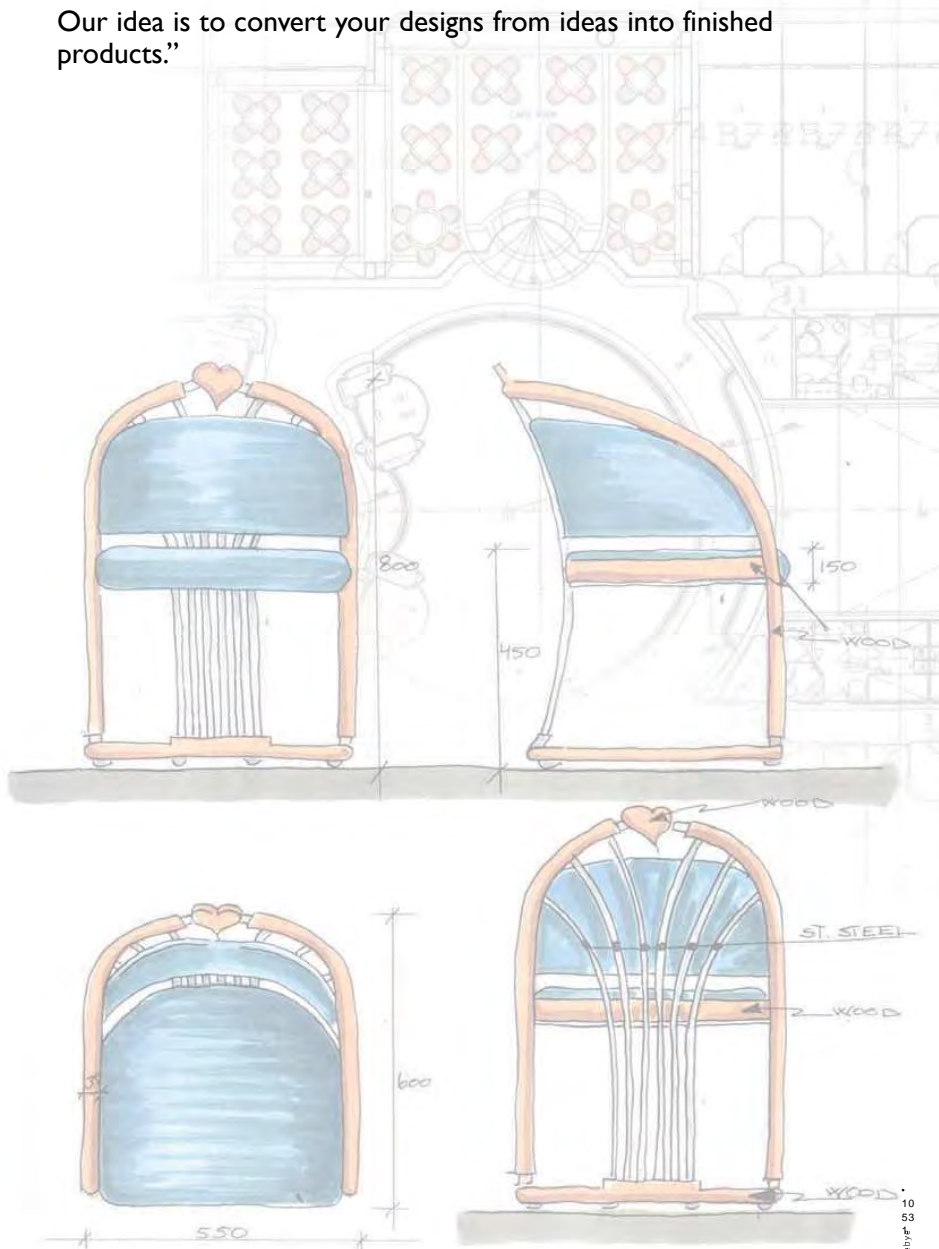

“Images by compliments from architect Njål R. Eide”

PART LIST/ACCESSORIES



- Standard table for reclining seats.
- Locking device to hold



Standard table for fixed seats



Retractable table. Complete including armrest, table and armrest top. Various finishes available



Newspaper net or newspaper pocket.

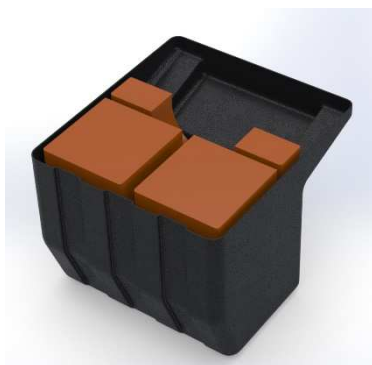

Various arrangements for stowing life west under the seat are available depending on type of chair and size of life west.
Size of life west must be
Alternatively we can offer life west bags made from fabrics.

PART LIST ACCESSORIES



Armrest. The above is a combined type for both "Senja" and "Bahama" chairs. We offer several solutions to accommodate various requirements.



For reclining chairs, closed armrests are standard. Upon request we deliver closed armrests for fixed chairs.



Armrest tops made from integral foam. Other solutions available upon request.



Bent double armrest top made from wood.

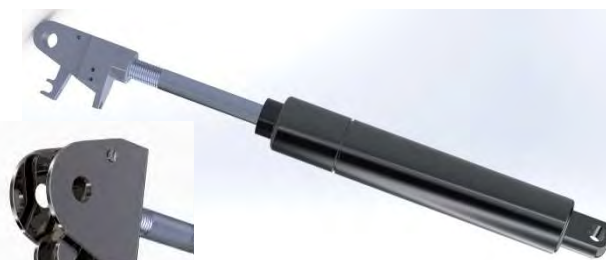

Reclining release system by push button.

PART LIST ACCESSORIES



Armrest. Half open armrest, for use with reclining chairs, where you have to hide the push button. Or as an option on senja chairs, for easy maintenance and cleaning.



Led lamp 12/24 volt, to be mounted on bahama chairs as an option.



USB outlet 12/24 volt, to be mounted into 45 or 90 mm armrest.

Power outlet 1230 volt, to be mounted into 90 mm armrest.



Molded leg in aluminium, to be used on all our seats where continues rail is an option. Perfect to be used on outdoor chairs. This leg is tested to 8 gcoll.

Life jacket, to be stowed under the seat in our life jacket boxes.



PART LIST ACCESSORIES



Cup holder.

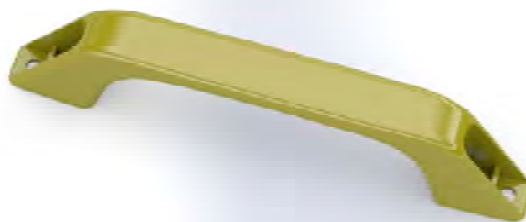

Grip handle.



Coat hook.



Seat belt when and where required.



Various solutions for foot rest are available.



Art.no: 13-I-089
Leather neck protection

Neck protection w/ zipper or velcro both in the front and the back for strong hold and easy removal. All chairs except "Senja Low" are prepared for antimaccasser with Velcro on the high back as standard.

PART LIST ACCESSORIES



Bracket for wall hung beam. A nice detail to ease cleaning of floors.



Base plate for fixing chairs to the floor. This may be used where rails are not required.



Floor rails are delivered in standard lengths of 6m. Optionally, the rails can be pre-holed for faster installation.

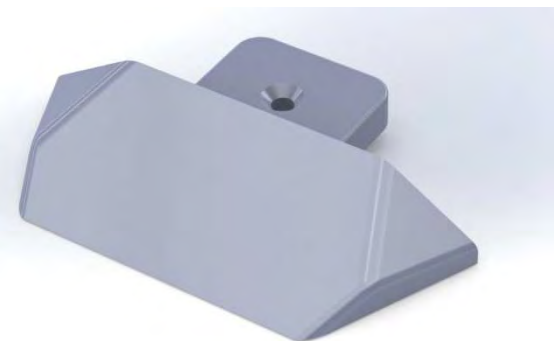

End cap for rail

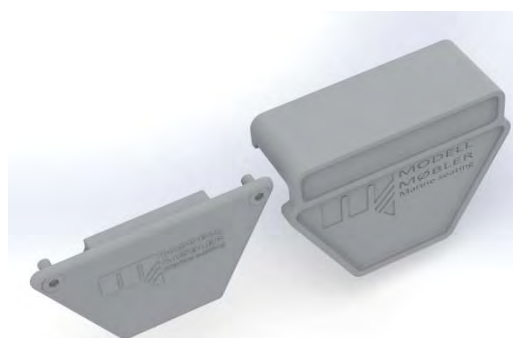

End cap for beam



PROSIMAR
PRO SIÈGES MARINE

Frédéric OLIVIER

www.prosimar.fr

+33(0) 616 977 845

fredolivier@prosimar.fr

La Rochelle - France

CUSTOM

FERRIES

FLUVIAL

MILITAIRE

NAVIRES À PASSAGERS

PASSERELLES

PÊCHE

WORKBOATS

YACHTS